

LS 17330

Primary Li-SOCl₂ cell

High energy density 3.6V , 2/3 A-size bobbin cell

Saft's LS 17330 cell is ideally suited for long-term applications (typically from 5 to 20+ years), featuring low base currents and periodic pulses.

Benefits

- High capacity and high energy
- High voltage response, stable during most of the lifetime of the application
- Wide operating temperature range (-60°C / +85°C)
- Low self-discharge rate, compatible with long operating life (less than 1% per year of storage, at +20°C, after 1 year)
- Superior resistance to corrosion
- Low magnetic signature

Key features

- Bobbin construction
- Well controlled passivation
- Hermetic construction with glass-to-metal seal
- Stainless steel can
- Non-flammable electrolyte
- RoHS and REACH compliance
- Made in China

Designed to meet all major quality, safety and environment standards

- Safety: UL 1642, IEC 60086-4
- ATEX: IEC 60079-11 (T4 rating at 85°C)
- Transport: UN 3090 and UN 3091
- Quality: ISO 9001, Saft Excellence System, continuous evaluation program
- CE: P/N: C10-0562

Typical applications

- Utility Metering
- Internet of Things
- Tracking systems
- Alarms and security
- Connected sensors
- Medical devices



Electrical characteristics¹

Nominal capacity (under 3 mA, +20°C, 2.0 V cut-off) ³	2.1 Ah
Open circuit voltage (at +20°C)	3.67 V
Nominal voltage (at 0.2 mA, +20°C)	3.6 V
Nominal energy	7.56 Wh
Pulse capability ⁴	Up to 120 mA
Maximum recommended continuous current	25 mA

For battery sizing, consult Saft

Operating conditions

Operating temperature range ⁵	-60°C / +85°C (-76°F / +185°F)
Storage temperatures (max recommended) ⁶	+30°C (+86°F)

Physical characteristics²

Diameter (max)	16.5 mm (0.65 in)
Height (max)	33.4 mm (1.31 in)
Typical weight	14.4 g (0.5 oz)
Li metal content	approx. 0.6 g

Termination suffix

CN, CNR	Radial tabs
2 PF, 3 PF, 3 PF RP, 4 PF	Radial pins
CNA	Axial leads
FL	Flying leads

Other configurations upon request

¹Typical values relative to cells stored up to one year at +30°C max.

²Sleeved cell.

³Dependent upon current drain, temperature, cut-off and cell orientation.

⁴Under 120 mA / 0.1 second pulses, drained every 2 minutes at +20°C from undischarged cells during 24 h, with 10 µA base current, yield voltage readings above 3.0 V after initial stabilisation. The readings may vary according to the pulse characteristics, the temperature, and the cell's previous history. Fitting the cell with a capacitor may be recommended in severe conditions or for high pulse currents. Consult Saft.

⁵Operation above ambient temperature may lead to reduced capacity and lower voltage readings. Consult Saft.

⁶For more severe conditions, consult Saft.

LS 17330

Primary Li-SOCl₂ cell

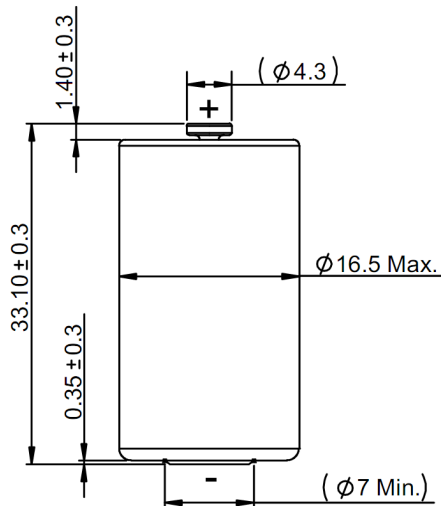

Dimensions in mm

Storage

- The storage area should be clean, cool (preferably not exceeding +30°C), dry and ventilated.

Warning

- Fire, explosion and severe burn hazard.
- Do not recharge, short circuit, crush, disassemble, heat above 100°C (212°F), incinerate, or expose contents to water.
- Do not solder directly to the cell (use tabbed cell versions instead).
- Do not remove the cells from their original packing before use.
- Do not store the cells in bulk to avoid accidental short circuiting.
- Do not mix new and used cells or cells from different origins.
- Mind the polarities of the cell.

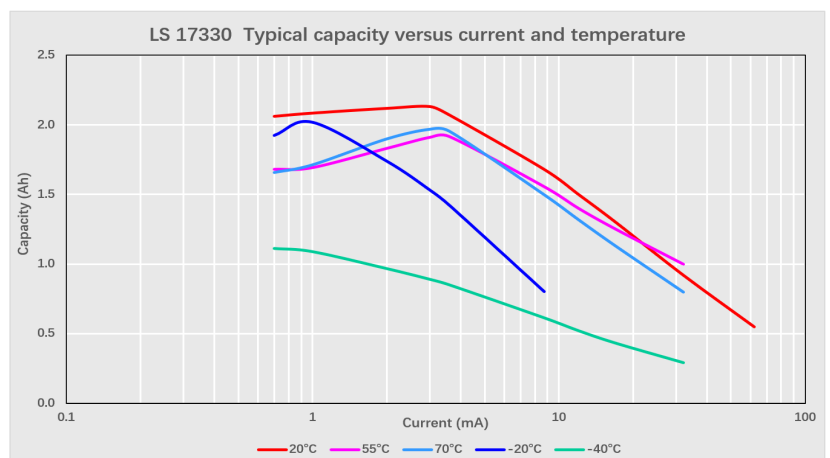
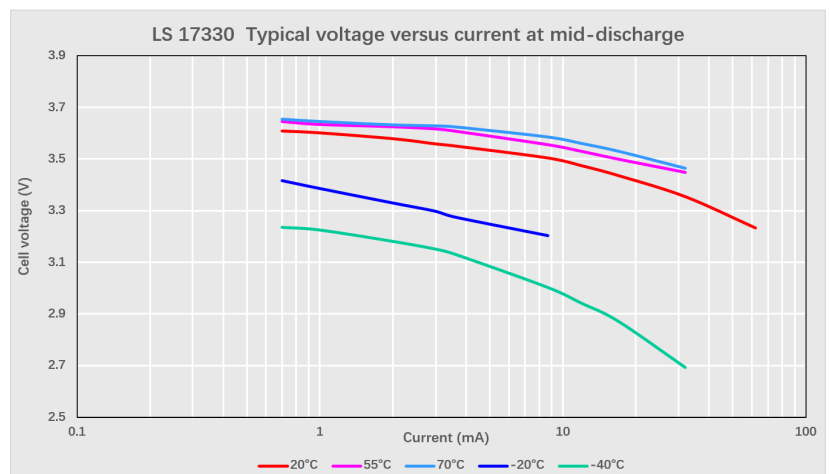
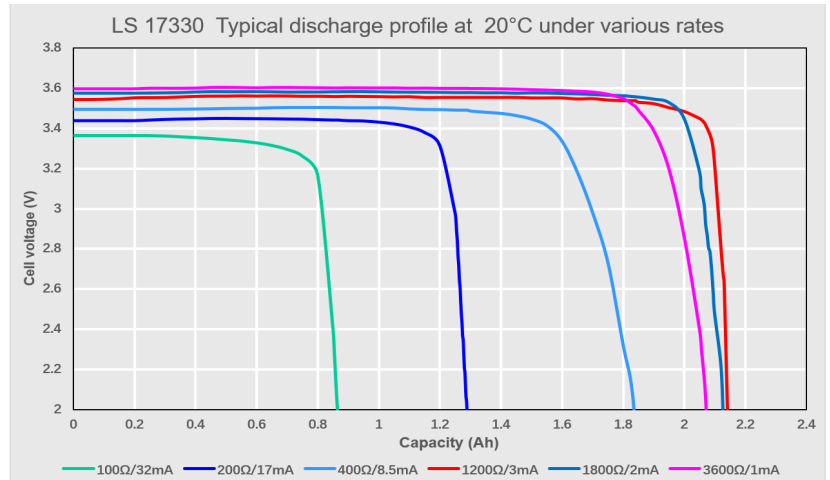

Block 8, 201 LianFeng Rd Xiangzhou District
ZhuHai 519030 China
Tel: +86 756 6290 288
Saft(Zhuhai FTZ) Batteries Co,Ltd

Saft, a subsidiary of TotalEnergies
S.A.S. au capital de 26 724 876 €
R.C.S. Nanterre 481 480 465
www.saft.com

Document N° 700024-EN-2510

Edition: Oct 2025

Data in this document is subject to change without notice and becomes contractual only after written confirmation.

Photo credits: © Saft